

tour with a cheltenham

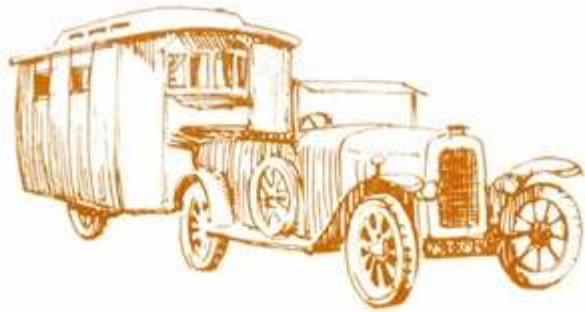



Our first caravan — a motorised one — was built on a lengthened ambulance chassis but serious drawbacks soon became obvious and a change was made to the trailer type. This was a vast improvement but still a bit primitive. Experience tells — especially some of the longer journeys such as the one to Morocco in 1933 — and the design has become more practical and more elegant year by year. Before being adopted, all new ideas are subjected to test over a period of 3—6 weeks and 3000—5000 miles.

At international rallies, Cheltenham lead the field of British caravans. In Israel (1964) half the British contingent was Cheltenham. At the international in Hungary (1966) there were no less than 56 Cheltenham. In 1968, at the Rallye des Amis — the second rally of Les Amis d'Outre Manche, the fraternity of the cream of continental caravan tourists — a check on the ten most popular trailer caravans showed Cheltenham once again at the top of the list — almost 50% more than any other make; and on a recent safari to the Sahara, there were more Cheltenham caravans than any other make.



The outright winner of the BRIGHTON TROPHY (1970 British Caravan Road Rally, Concours d'Elegance) featured a Cheltenham SABLE which also claimed the CLASS B TRADE event in what the judges called — 'the best concours entry in the history of the rally'. In the YORKSHIRE TROPHY RALLY (1970) it was a Range Rover and ROEBUCK which beat the field, incurring least penalties in both the road and track sections and attaining the fastest speed on the special section.

These are just some of the reasons why TODAY, in the world of TOURING, wherever you roam, CHELTENHAM is the byword.

CHELTENHAM CARAVAN COMPANY LIMITED

'CHELTENHAM' *Special Features-*

- Glassfibre roofs, ends and many other parts, give pleasing appearance, great strength and low maintenance costs.
 - Roof, side, and end walls are insulated with expanded polystyrene.
 - A view through the Caravan when towing — using the standard car interior mirror.
 - A really light caravan capable of being towed at high speeds or for long distances without strain.
 - A practical, compact, yet spacious layout.
 - End kitchen on all models except Nyala and Roebuck.
 - All models are fitted with a foot water pump and tuck-away faucets.
 - Hydraulic coupling neatly enclosed by a shroud.
 - Gas and electric light.
 - Elegant lines further enhanced by wheel trim.
 - Fitted carpets are supplied on top of waterproof felt on all models — you choose the colour.
 - A wide range of colour schemes and upholstery materials to choose from.
 - All models have stable doors on the near side. Glazed doors are an optional extra.
 - Awning rails are fitted to all models. On the Springbok and Fawn they go all round.
 - Hot-plate, screw-type jockey wheel, side lights, rear lights, stop lights and flasher lights are all included.
 - Electric wiring is arranged by means of a seven core cable so that interior as well as full exterior lights are included.
 - All models have at least one bed over 6' 2" in length. The single beds are also, extra wide.
 - Details of extras available such as full Cooker, Refrigerator, electric reversing stop, etc., may be obtained from your Dealer.
- Our policy is to incorporate improvements — therefore our productions may not conform to illustrations, descriptions, or drawings published here or elsewhere.

SERVICE

500 MILES or 2 MONTHS SERVICE

To obtain this free service, after 500 miles towing or within two months of purchase, whichever occurs first, all the owner has to do is, by arrangement, take his caravan to an authorised Cheltenham distributor.

The distributor then checks the chassis, adjusts brakes, etc., giving necessary lubrication. Checks and adjusts cupboard catches, gas and electric lights, drawer retainers, etc.

When collecting the caravan upon completion, the customer checks that the job has been done to his satisfaction and then signs the distributor's chit to enable him to obtain payment from us. There is no charge to the customer for this service; it is part of the after-sales service provided for Cheltenham owners, through close co-operation between this company and its distributors.

CHELTENHAM OWNERS CLUB

Anyone who owns a Cheltenham caravan is eligible for membership of The Cheltenham Owners Club — with its handsome car badge in silver, green and cream; pennant, club tie and brooch. Old hands and new comers to caravanning both belong to it and meet in happy holiday mood and environment at Rallies and the Winter Luncheon. For further particulars, apply to the Hon. Secretary, Mr. C. H. Gardner, c/o Cheltenham Caravan Co. Ltd., 205 Leckhampton Road, Cheltenham. Telephone 53695 and 59296.

Features a lantern roof. This type of roof was always attractive but when built-up in the normal way was heavy and prone to leakage.

Our new type, being moulded in one piece, is lighter and of course, there are no joints to leak!

Its reintroduction still further enhances the appearance of this model.

The roof incorporates top awning rails fitted integrally with gutter all round roof.

16' 6" (503 cm) long, 6' 9" (206 cm) wide and 6' 5" (195 cm) headroom.

Extensive use is made of modern plastics, the moulded bay at either end giving graceful exterior lines, extreme lightness and sturdiness to this model. All of our models have 'wrap round' end sections that eliminate joints at corner which can otherwise be a source of trouble. The rear end bay section makes the kitchen 'open' and pleasant to use. Ventilation louvres for the refrigerator and lavatory compartments are moulded integrally with the section, which adds to the attractive appearance. The toilet compartment is a one-piece self-coloured G.R.P. unit with rounded corners, attractive and hygienic. Two 13 watt fluorescent lights.

the luxurious SPRINGBOK



The layout of the Springbok is shown on the Key to the plan view. other outstanding features are:—

- Fibreglass roof, front, and back.
- Triangulated chassis with independent suspension and shock absorbers. 6.70 x 13 — 6-ply tyres.
- The interior is a revelation in caravan design — walls and furniture of polished oak, ceilings white rippled P.V.C. finish. Spacious compactum, chest of drawers, shelves, roof lockers, large and small table, a smart cocktail cabinet and magazine rack. Fitted carpet.
- The curved kitchen section is very compact with full oven cooker. Locker for pots and pans, and rubbish bin, large ventilated food cupboard specially designed to take a refrigerator, sink and draining board with foot water pump, locker for water carrier (supplied) and storage. Roomy crockery cabinet and a cutlery drawer — in fact a very neat layout.
- A flued gas operated convector heater is neatly installed in the base of the wardrobe.
- Toilet — a wash basin with built-in outside waste, soap dish, tooth mug and tooth brush holder are all included. Borrowed light panel.
- Beds — two single with special spring base and 5" thick plastic foam mattresses (5" foam mattresses on solid base alternatively), padded sloping backrests, hinged for moving at night give the last word in comfort. The sliding unit double bed has 5" mattresses which are easily and quickly made up and in the daytime provide a charming lounge effect.
- With four opening windows on each side of the lantern roof, first-class adjustable top ventilation is assured. Also good headroom and plenty of light. Top awning rails fitted integrally with gutter all round roof.



- A Single beds.
- A1 Nearside single bed extension.
- B Chest of drawers.
- C Dinette sliding double bed. Alternative settee double bed.
- D Toilet with tip-up wash basin G.R.P. Fixed vents end and side.
- E Full oven cooker.
- F Ventilated food cupboard or space for refrigerator. Cutlery drawer.
- G China Cabinet.
- H Combined sink and draining board and foot pump.



SPRINGBOK—views of the interior. The refrigerator shown in the rear view (above) is an optional extra. The chest and hinged table can be seen in the front view (below).

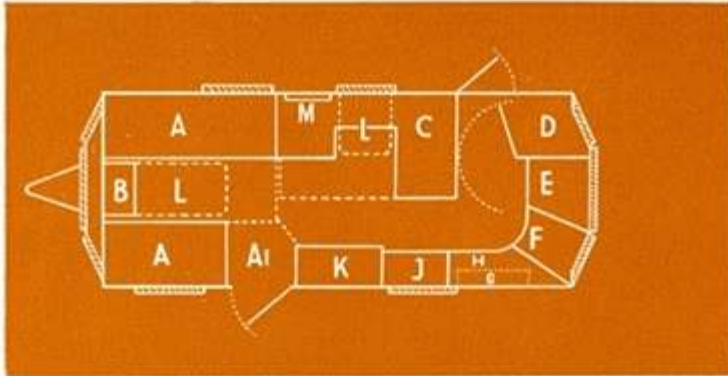

- J Drawers and locker.
 - K Compactum with flued gas heater at base.
 - L Hinged tables.
 - M Paper rack.
- Roof lockers above offside single and double beds.
Also above sink unit.
Book shelf above nearside single bed.

SHIPPING SPECIFICATIONS

Ex-works weight: 17½ cwt. (902 kg)
Overall size: Length 18' 7" (566 cm)
 Width 6' 9" (206 cm)
 Height 8' 1" (246 cm)



the elegant NYALA



Similar in size and appearance to the Puku 2, the Nyala has an entirely different layout, with ample working surface and cupboard accommodation. In the front there is a dinette bed, 6' 3" x 4' 2" consisting of 5" polyurethane mattresses on perforated bases.

The van can be divided either by a fitted curtain across the centre, or the track can be put round the single beds so that when children are asleep all facilities of the van are just as available at night as in the day-time.

Bay windows both ends as on all models, except Fawn.

A foot pump is fitted for the wash basin to draw water from a portable container situated inside or outside as desired. This is a feature of all our models. Fitted handy to the wash-bowl is a rubbish disposal unit.

Standard model includes gas lighting and two 8 watt fluorescent lights; gas griller, etc.





Interior of Nyala looking to rear of van



Interior of Nyala looking to front of van



- A Double bed dinette.
- A1 Table — also forming double bed A. A. A1.
- B Boot locker.
- C Ventilated food cupboard or space for refrigerator.
- D Sink and draining board — C, D and E form side-board unit with lockers, water storage, room for refrigerator. Roof locker extends full width above D and E.
- E Cooker hotplate — room for oven cooker.
- F Toilet G.R.P., fixed vents end and side.
- G Chest of drawers — roof locker above G and H.
- H Single bed. Bunk bed above, permanently hinged. Curtain on rail around H.
- J Wardrobe.

SHIPPING SPECIFICATIONS

Ex-works weight: 14 cwt. (724 kg)
 Overall size: Length 17' 0" (518 cm)
 Width 6' 6" (198 cm)
 Height 7' 10" (239 cm)

the graceful ROEBUCK

Our latest model is a four berth 15' 0" (457 cm) long, 6' 6" (198 cm) wide with 6' 3" (191 cm) headroom. Similar in appearance to the Nyala and Puku, this model has four single beds, the fourth being a bunk. A conversion is also available so that the front single beds can be used as a double bed if desired, (this gives a double bed 4' 4" wide). Despite including four single beds in the layout, none of the beds is skimped. As on all Cheltenham models, one bed is 6' 2" long, the other single beds are full length and a good width.

The kitchen is compact and practical, with crockery storage locker running the full length above the kitchen. The separate cupboard under the rear window is capable of taking a refrigerator if required. In the front end you have the unique Cheltenham chest of drawers and table unit; well proven and popular as used on the Sable.

Even with the front beds made up as a double, there is ample floor space and complete freedom to use the offside rear door.

As on the Nyala, a curtain is provided to partition off the rear single bed and bunk.

The lid for the draining-board is hinged to form extra working space when required.

The gas lamp at the rear is standard. The lamp at the front (top illustration opposite) is an optional extra. Two 8 watt fluorescent lights are provided.



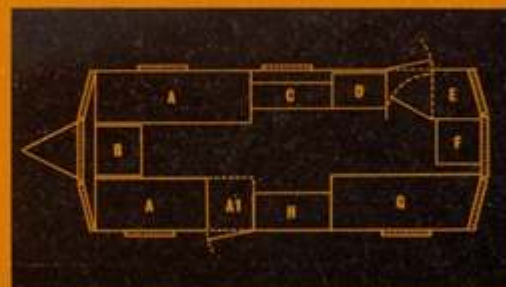

- A Single beds.
- A1 Floor Space in day time. Bed end moves to form single bed A, A1.
- B Chest of drawers with hinged extending table on face.
- C Combined sink and draining board. Storage below.
- D Cooker recess with storage below. China cabinet, roof locker extends above kitchen units C and D.
- E Toilet compartment G.R.P. with fixed vents.
- F Food cupboard or space for refrigerator.
- G Single bed with hinged bunk above and hinged backrest.
- H Compactum.

Length 15' 0" (457 cm)
 Width 6' 6" (198 cm)
 Headroom 6' 3" (191 cm)

SHIPPING SPECIFICATIONS

Length 17' 0" (518 cm)
 Width 6' 6" (198 cm)
 Height 7' 10" (239 cm)
 Ex-works weight 14½ cwt. (737 kg)



the spacious PUKU 2

Our most luxurious two berth model, 15' 0" (457 cm) long, 6' 6" (198 cm) wide with 6' 3" (191 cm) headroom. All of the pleasing and practical features of the Sable are included, and there is added wardrobe accommodation, a built-in flued gas convector heater, and a shower compartment with roomy and extensive washing facilities. The washroom recess is a self coloured G.R.P. unit — like the lavatory compartment, with curved corners to afford an hygienic unit. There is additional storage, working and floor space compared with the Sable.

- Designed for those caravanners who want to be really mobile but also want to be away from home possibly for months on end and wish to take all the necessary equipment in great comfort.
- Morlite roof opening section 4' x 2' affords superb ventilation and light inside the caravan.
- Awning rail fitted beneath gutter.
- Two doors, end kitchen, toilet and shower rooms. Extensive working surfaces. Plenty of cupboards, two chests of drawers, ventilated food cupboard with provision for a refrigerator. Ample roof lockers and plenty of shelves. Special ventilation for refrigerator is incorporated.
- A compactum plus a gentleman's wardrobe. Fitted gas operated flued convector heater and fitted crockery/cocktail cabinet. Foot water pump to sink with tuck-away faucet. Rubbish container.
- Beds — two single, with 5" polyether foam mattress, extra wide with padded sloping backs. Special spring bases available as an extra.
- Two 8 watt fluorescent lights are provided.



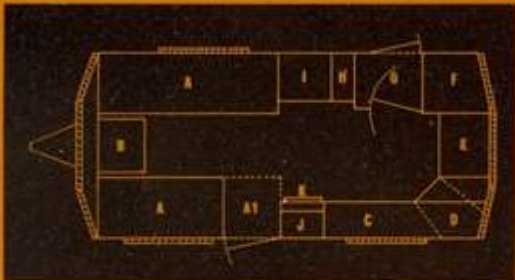

- A Single beds.
- A1 Floor space in day time. Bed end moves to form single bed A, A1.
- B Chest of drawers with hinged table.
- C Working surface with sink, drainer and cupboards below.
- D Food cupboard or space for refrigerator.
- E Cooker unit.
- F Toilet G.B.P. fixed vents end and side.
- G Shower room and washing facilities.
- H Gentleman's wardrobe.
- I Compactum.
- J Cocktail and china cabinet.
- K Flued gas fire.
- C, D, E. are all working surfaces.

SHIPPING SPECIFICATIONS

Ex-works weight: 14½ cwt. (737 kg)
 Overall size: Length 17' 0" (518 cm)
 Width 6' 6" (198 cm)
 Height 7' 10" (239 cm)



Washing compartment with shower



PUKU—view of interior looking to rear of van. The glazed stable door is an optional extra.

the world-famous SABLE

13' 4" (406 cm) long, 6' 6" (198 cm) wide with 6' 3" (191 cm) headroom. Supreme comfort for two, elegant appearance with bay window at rear as well as front, plenty of space and maximum mobility: the Sable is firmly established as the answer to all these requirements.

The layout is shown on the floor plan and key, demonstrating clearly—

- A wealth of working surfaces and storage cupboards. Kitchen end has been designed to take advantage of extra space provided by bay window. Provision is made for fitting a refrigerator. Chest of drawers, ventilated cupboard for food, four other lockers for stowage. Detachable rubbish bin. Compartment behind will hold either one water carrier and one cylinder, or two carriers or two cylinders. The flexible lead from the foot pump is led into this compartment ready to go into the water carriers which stow in here. Cutlery and cosmetics drawers. Fitted crockery and cocktail cabinet. Point for gas fire.
- A spacious open layout with plenty of floor space: enough even for an occasional bed on the floor if wanted.
- Two doors.
- Two luxury sized single beds, both 2' 2" wide, and 6' 3" and 5' 11" in length respectively. Both using 5" mattresses on perforated bases with padded sloping back rests. The near-side single bed is long enough to put your feet up for an afternoon nap without extension. When extended for full length you still have the off-side door available for use.
- Morlite roof opening section 4' x 2'.
- Choice of exterior and interior colours and finishes, upholstery, carpet, etc.
- Suspension — as Springbok but with lighter springs and 5.90 x 13 tyres.
- Two 8 watt fluorescent lights are provided.



The glazed stable door is an optional extra.

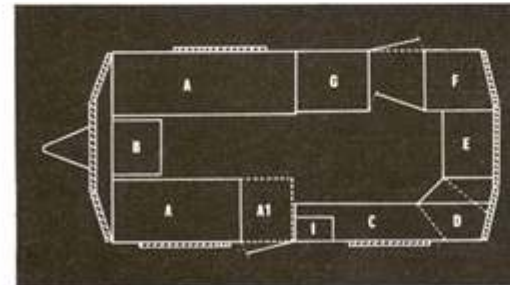

- A Single beds.
- A1 Floor space in day time. Bed end moves to form single bed A, A1.
- B Chest of drawers with hinged table.
- C Working surface with sink, drainer and cupboards below.
- D Food cupboard or space for refrigerator.
- E Cooker unit.
- F Toilet G.R.P., fixed vents end and side.

- G Compactum.
 - I Cocktail and china cabinet.
- C, D, E, are all working surfaces.

SHIPPING SPECIFICATIONS

Ex-works weight: 12½ cwt. (648 kg)
 Overall size: Length 15' 5" (470 cm)
 Width 6' 6" (198 cm)
 Height 7' 9" (236 cm)

the lightweight WATERBUCK

Bay window at rear end. 13' 4" (406 cm) long, 6' 6" (198 cm) wide, with 6' 3" (191 cm) headroom. Designed for the small car owner who wants comfort on site and on tow with maximum mobility. It is available as either a three or four berth model, the latter having a stretcher type bunk in addition to the single bed.

- Glassfibre roof, front and back.
- Morlite roof opening 4' x 2'.
- Compact end kitchen which can be used even when single bed and bunk are in use. Foot water pump to sink with tuck-away faucet. Self-contained lavatory compartment.
- Good size ventilated larder with extra working surface covered in Formica or similar material, and with fitted crockery storage above.
- Division curtain between wardrobe and chest of drawers.
- Choice of soft trimmings, interior finishes and exterior colours. Fitted carpet.
- Dinette double bed at the front end, with the table forming centre section at night, with 5" mattress. Single bed, extending simply at night, using 5" mattresses on perforated base. In the 4-berth a detachable and easily erected bunk is positioned above the single bed when required. The bunk is one unit with canvas top, and is permanently hinged to side of van.
- Compactum with shelves and generous hanging space. Chest of drawers, wall cupboard and roof-lockers and shoe-locker at front end for extra storage.
- Suspension — independent suspension, and an hydraulic hitch, used so successfully on the remainder of the range, are fitted on the Waterbuck.



A Double bed dinette seats.
 A, A1 Double bed using table A1.
 B Chest of drawers with wall cupboard above.
 C Single bed.
 C1 Floor space in daytime. Bed and forms single bed C, C1 at night. Bunk bed above C, C1.
 D Kitchen unit with grill, combined sink and draining board with foot pump, lockers beneath and above.
 E Toilet. Fixed vents end and side.
 F Food cupboard or space for refrigerator and crockery cabinet above.
 G Compactum.

SHIPPING SPECIFICATIONS
 Ex-works weight: 12½ cwt. (635 kg)
 Overall size: Length 15' 5" (470 cm)
 Width 6' 6" (198 cm)
 Height 7' 10" (239 cm)



the fleet FAWN

This, as the name implies, is the smallest in our range and is now a proved winner.

Generally speaking, vans of this length are too small to be comfortable. Five can feed in this model quite easily, and a 6 foot person need not feel cramped by day or night — one bed is 6' 3".

- Two berth, 11' 2" (340 cm) long, 6' 3" (191 cm) wide, with 6' 3" (191 cm) headroom. The body styling has a G.R.P. roof coming down to top of window level, and with the rainwater gutter moulded into the exterior profile. The roof incorporates top awning rails fitted integrally with gutter all round roof. The G.R.P. front and rear sections have deep 'wrap round' sides, and a 4' 6" rear window, top hinged, gives panoramic views.
- Apart from the beds, main features are an end kitchen, compactum type wardrobe, cooking and washing facilities, and a separate toilet compartment.
- Mattresses on this model are 5" polyurethane foam on solid bases — covers to choice.
- One fluorescent light is provided.



Interior of Fawn looking to rear of van

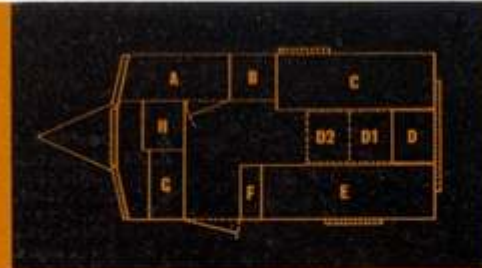

- | | |
|--|---|
| <p>A Toilet compartment.</p> <p>B Compactum type wardrobe.</p> <p>C Single bed with hinged back rest. Large storage space below — roof locker above.</p> <p>D Chest fitted 3 drawers and a locker. Hinged top extends to position D1 or D2 as required.</p> <p>E Single bed 6' 3" with locker under and locker and china cabinet above.</p> <p>F Stores cupboard with working surface above.</p> | <p>G Combined sink and drainer with cupboard under, foot pump and space for refrigerator.</p> <p>H Hotplate with locker under, and plate rack. Complete inside and outside electric lighting seven core cable supplied. Gas lighting also included.</p> <p>SHIPPING SPECIFICATIONS
 Ex-works weight: 11 cwt. (559 kg)
 Overall size: Length 13' 4" (406 cm)
 Width 6' 3" (191 cm)
 Height 7' 8" (234 cm)</p> |
|--|---|

Practical features of a 'CHELTENHAM'

DOOR RETAINERS: these are positive and will hold the door in any wind.

RECESSED DOOR HANDLES: no risk of them being 'caught'.

BUILT-IN SIDE LIGHTS: to avoid cutting the panel, recesses are moulded into it so that if rain should get past the lamp glass, it cannot get into the van.

ROBUST HANDLES OR GRAB RAILS.

DRAWERS THAT ARE SELF-LOCKING: you will not find them on the floor when you stop for the night.

DUST HOLE: standard on Springbok and optional on other models. It can also assist ventilation.

BOTTLE CLIPS: very useful.

STAINLESS STEEL WAISTLINE: this is smarter looking and will remain so much longer than aluminium moulding.

FOLDING HOOKS: on certain models; these are shapely things that certainly do not spoil the interior — they are a godsend at night!

DRAUGHT EXCLUDER TO ALL EXTERIOR DOORS: very necessary in this climate.

RUBBISH BINS: as fitted to certain models, are detachable for easy emptying and have rounded corners for easy washing.

FITTED CROCKERY CUPBOARDS are designed to accommodate contemporary pottery.

FRONT CHEST AND TABLE: the chest is designed in accordance with modern trend. Note the three positions for table, (a) folded completely out of the way when not required, (b) half open when required for writing a letter etc., and (c) fully open to give ample space for meals etc.

INTERIOR ELECTRIC LIGHTS: Every model also has gas lighting.

GAS STOWAGE INSIDE: no unsightly cylinders stuck around.

WORKING SURFACES: all in a pleasing shade and style of heat-resistant melamine.

LARDERS: are ventilated underneath and at the back.

ROOFLIGHTS: there is considerable overlap so these can remain open except under very adverse conditions. A lifting mechanism is incorporated.

LOW WINDOWS: for view through and good visibility inside vans.

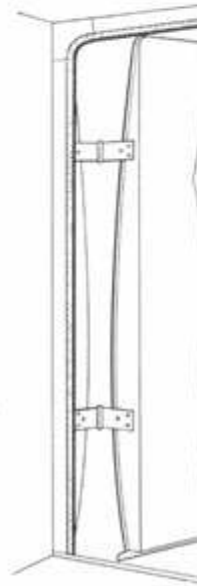

SPRUNG BASES FOR SINGLE BEDS with nylon elastic straps which have just that 'give' which extra comfort demands are available as extras on all models.

DOUBLE BED CONVERSIONS: on all models which have single beds with solid bases, a special platform can be supplied as an extra which enables the standard mattresses to be placed side by side and rotated through 90°, thus forming a wide double bed. The layout may then be used either as two singles or one double.

EXTENDED BED END: special design ensures easier handling. **PLATE RACKS:** are fitted as standard on all models.

SINGLE BEDS: the back rests are padded and hinged in such a way that they are sloping to support your back in day time and fall back out of the way at night. The front fascia slope back 3 inches to allow easier ingress. This also improves the appearance of the van.



COLOUR SCHEMES

Exterior treatment.

All models are finished in Dover White as standard. As an alternative they can be finished in Vellum, Pearl Grey, Fiesta Yellow or Ice Blue. Further, the trim (gutters, window hoods, valances, two bar shroud and wheels) may be in a contrasting colour; this second colour can be any of those already mentioned or Carnation Red, Thames Blue, Powder Grey, Sky Blue, and Fiesta Yellow.

Interior decor.

Standard models are finished in polished oak furniture and walls. As alternatives, they are available with walls and furniture in 'limed' oak. There is a wide choice of upholstery patterns offered in our range, and good quality patterned carpet is available in a choice of colours. All above alternatives are at no extra charge.

CONSTRUCTION DETAILS

All floors are tongued and grooved boards. Insulation felt on all floors underneath carpet.

Sides on all models are curved. Besides giving a graceful shape, they also make the shell extremely strong and reduce wind resistance.

Roofs on all models are made of fibreglass reinforced polyester resin, and are moulded in one piece with gutters incorporated. This ensures that there are no roof or gutter joints which might give rise to leakage. All models have similarly constructed G.R.P. bay front units. Also, the rear end units are made in this manner. Fibreglass reinforced polyester resin lends itself to attractive shapes: it is extremely strong and light, has low maintenance costs, is easily repaired, and is a thermal and acoustic insulator.

Side panels are clad in 18 swg aluminium — a heavier gauge than usual, to give increased strength, durability and rigidity. Expanded polystyrene insulates all shell cavities.

The 'CHELTENHAM'

TRIANGULATED CHASSIS

The independent suspension has been used most successfully for many years and is fitted on all models. Shock absorber incorporated within the spring.

The trailing arm is carried in nylon bearings which require no lubrication. Neither do the rubber bushes which carry the shock absorber. Large brakes (9") are used on the "Springbok"; all other models have 8" brakes with wide shoes. They have triangulated chassis members for rigidity. All brakes are of the rod-operated centre pull type with compensating mechanism. All chassis are designed for use behind private cars. If a commercial type vehicle is to be used we should be notified.

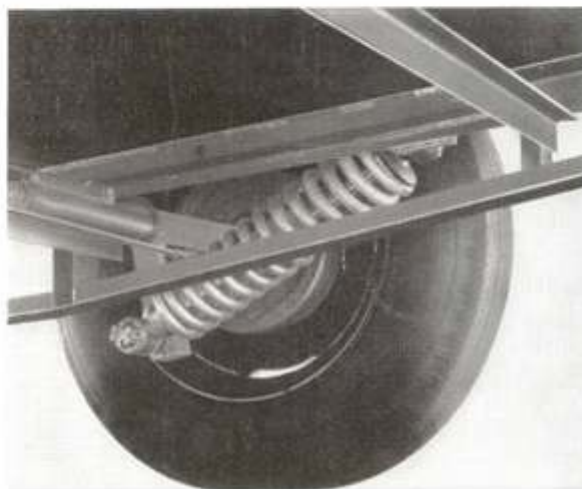

The hydraulic shock absorber on the head, which is standard on all models, ensures that the brakes are applied very smoothly and yet allows them to act powerfully when required. It also takes care of any tendency to 'hunt'. A further refinement is the separate car type hand-brake which can also be applied by the car in the event of a break away. Electric reversing stop is now available.

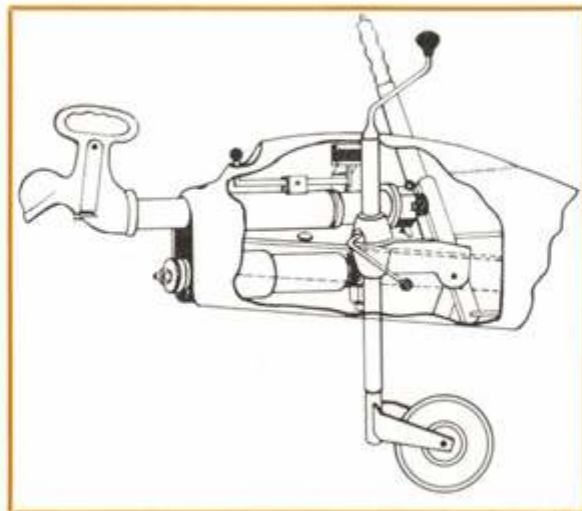

TERMS OF BUSINESS

All prices are ex-works. Orders should be accompanied by deposit of ten per cent, the balance being payable on delivery except when Hire Purchase arrangements have been made. Orders will be executed to time promised unless through circumstances beyond our control, but no responsibility can be accepted for late delivery.

Orders are accepted on the understanding that price charged will be that ruling at time of delivery. The Company's policy, however, is to avoid any increase during the season if at all possible.

None of our products may be exhibited at any show without our written permission.

*Over fifty years'
experience of practical
caravanning in
design and construction*

CHELTENHAM CARAVAN CO. LTD.

Antelope Works
205 Leckhampton Road
Cheltenham
Telephone: 53695 & 59296